

1

2

3

4

No	Revizyon Tarihi ( Revision Date )	Revizyon Açıklaması ( Purpose of Revision )	Revizyon Numarası ( Revision Number )	Onay ( Approval )
1				

A

B

C

D

A

B

C

D

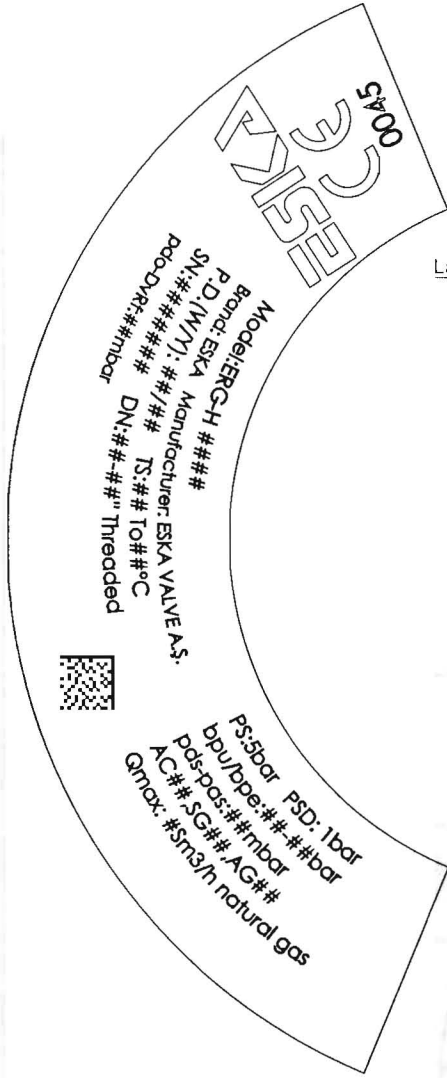

Laser Marking

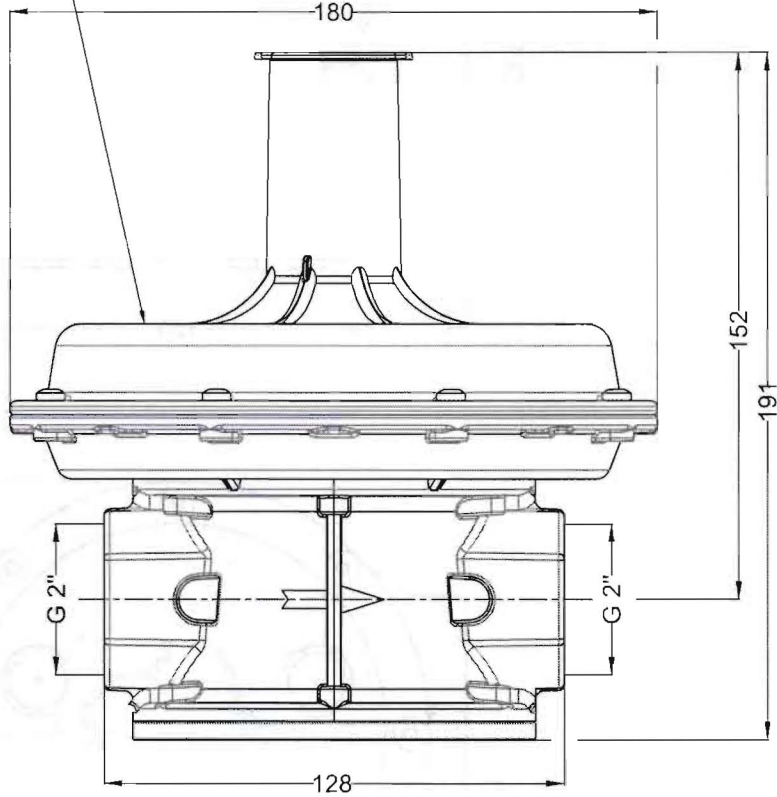

Q=	500 SCMH
Ps=	5 bar(g)
Pin(Bpu/Bpe)=	5 bar(g)
Pout(Pds/Pas)=	300mbar(g)
Prelief=	N/A
Accuracy Class%=	AC10,SG30
Working Temperature=	-20 to 60°C

Mühür kutuya atılacaktır.  
The seal will be put in the box.

Ad - Soyad ( Name And surname )		Tarih ( Date )	İmza ( Singature )	Referanslar ( Preferences )	ESKA				
Çizen ( Drawn by )		Berk ÖZGÜL	20.10.2023	-		Açıklama ( Explanation )			
Kontrol Eden ( Checked by )		Duygu ALEMDAR	20.10.2023	-	S.T.E.T.				
Onaylayan ( Approved by )		Soner USTA	20.10.2023	-		S.T.E.T.			
Açısal Toleranslar ( Angular Tolerances )		İşaretleme ( Markings )			Resim / Parça Adı ( Drawing / Part Name )				
0° - 10° ± 30'	10° - 50° ± 1°	Geçici ( Temporary )	Referans ( Reference )	Temel ( Basic )		Fikstür ( Fixture )	Kontrol ( Control )	Ölçek ( Scale )	Kağıt Boyutu ( Page size )
		=	( )	□	< >	[ ]	1/1		
Doğrusal Toleranslar ( Linear Tolerances )		Resim No ( Drawing No ) / SAP No			Sayfa No ( Page No )				
50° - 90° ± 1°30'	90° - 180° ± 2°	0,5 - 6 mm ± 0,1 mm	6 - 30 mm ± 0,2 mm	30 - 120mm ± 0,3 mm	120-400mm ± 0,4 mm	400-1000mm ± 0,5 mm	1/1		
Bu teknik resim ESKA VALVE A.Ş.'ye aittir, izni olmadan kullanılamaz ya da kopyalanamaz. ( This is what the drawing ESKA VALVE A.S. belongs to be used or copied without permission. )							0216.01.067 / 1000003370		1/1
Aksi belirtilmediği sürece boyutlar mm'dir. ( Unless otherwise stated, dimensions mm. )									

1

2

3

4

No

Revizyon Tarihi  
( Revision Date )Revizyon Açıklaması  
( Revision Description )Revizyon Numarası  
( Revision Number )

Onay ( Approval )

1

**ESKA** GAS FILTER 1 1/2"  
DN40 EGF-H 6040

Manufacturer:ESKA VALVE A.Ş.

Brand : ESKA VALVE

PN6 DN40-1 1/2"

Ambient Temp. : -20.....+60°C

Serial Number:00001/22

www.eskavalve.com

Production Date (YMW): 23/

Sıkıya 1.0rg.Sn.Blg Mh.11 Cd.

No: 6-6 Antalya/Sakarya

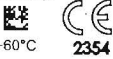

2354

01123456789

01123456789

Design and

Manufactured

in TURKEY

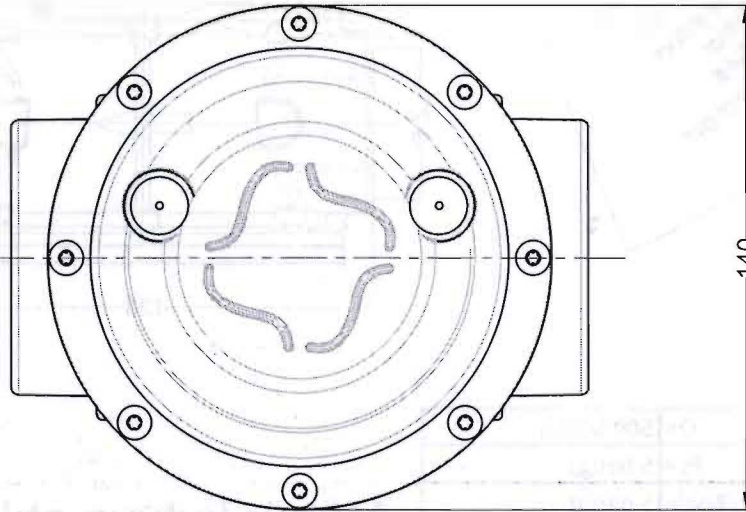
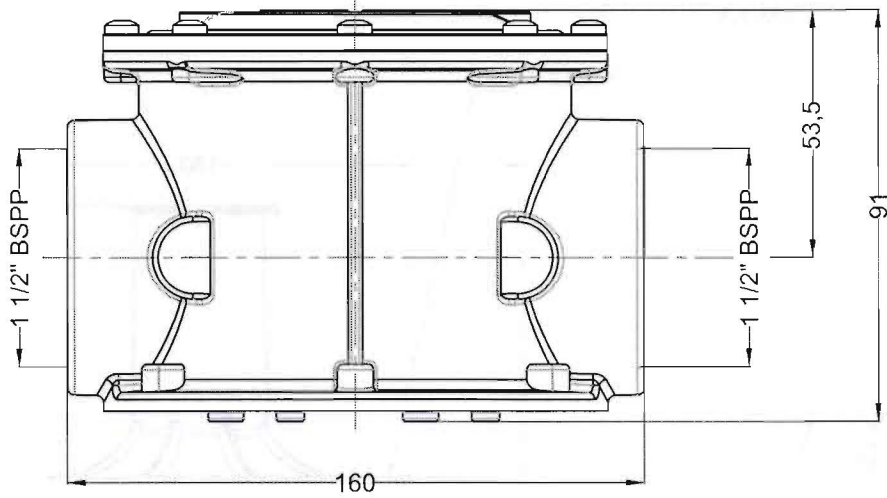

		Ad - Soyad (Name And surname)		Tarih ( Date )		İmza ( Singature )		Referanslar (Preferences)		<b>ESKA</b>	
Çizen (Drawn by)		Berk ÖZGÜL		06.07.2023				Parça Ağırlığı (Part Weight)			
Onaylayan (Approved by)		Soner USTA		06.07.2023				Malzeme Kalitesi (Material Quality)			
								Yüzey İşlemi (Surface Treatment)			
Açısal Toleranslar (Angular Tolerances)		İşaretleme ( Markings )						Resim / Parça Adı (Drawing / Part Name)		Açıklama (Explanation)	
0° - 10° ± 30'	10° - 50° ± 1°	Geçici (Temporary) =	Referans (Reference) ( )	Temel ( Basic ) □	Fikstür ( Fixture ) < >	Kontrol ( Control ) [ ]	EGF-H 6040 BSPP		STATÜGAZ		
Doğrusal Toleranslar ( Linear Tolerances )		Resim / Parça Adı (Drawing / Part Name)		Ölçek (Scale)		Kağıt Boyutu (Page size)					
50° - 90° ± 1°30'	90° - 180° ± 2°	0,5 - 6 mm ± 0,1 mm	6 - 30 mm ± 0,2 mm	30 - 120mm ± 0,3 mm	120-400mm ± 0,4 mm	400-1000mm ± 0,5 mm	EGF-H 6040 BSPP		1/1	A4	
Bu teknik resim ESKA VALVE A.Ş.'ye aittir,izni olmadan kullanılamaz yada kopyalanamaz. ( This is what the drawing ESKA VALVE JSC. belongs to be used or copied without permission )						Resim No (Drawing No) / SAP No		Sayfa No (Page No)			
Aksi belirtilmediği sürece boyutlar mm'dir ( Unless otherwise stated,dimensions mm. )						0359.02.008 / 1000001591		1/1			