

# Water Flow Indicator (AWFD)



## 4. Adjustment



- The Arrow
- Rotary Knob

### Delay Function Adjustment

- 4.1 The original set time is 30 seconds, if need to adjust the time, rotate the rotary knob to make sure the arrow direct to the scale, increase time with clockwise rotating, and reduce the time by anticlockwise rotating.
- 4.2 The unit of the scale is second, the accuracy is 50%.
- Caution: The delay time must not exceed 90 seconds when adjusting the rotary knob.

## 5. Operation Test

- 5.1 System full of water, check if there's leakage around the water flow indicator, verify the leakage position.
- leakage between the connecting plate and the saddle  
Open the cover, fasten the hexagon nuts.
  - leakage between the saddle and pipe  
Fasten the U-bolts alternately, make sure the sealing surface is even & uniform.
  - leakage from the rod sealing gasket  
Contact the customer service agent to replace the rod sealing gasket  
If leakage found except for a, b, and c, drain the water in the system, remove the saddle, check if there's other material or inclusion under the sealing gasket, make sure the pipe should be no defects of bulge or sunken, then install again.

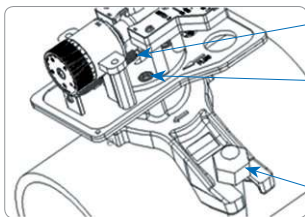

- Rod Sealing Gasket
- Hexagon Nut
- U-Bolt Nut

### 5.2 Adjustment of Delay Time

Adjust the rotary knob, if delay time is not as desired, to increase time with clockwise rotating, and reduce the time by anticlockwise rotating.



- Rotary Knob

## 6. Removal

When need to remove the water flow indicator due to improper operation or other reasons.

- Turn off electrical power, drain the water of the pipe.
  - Loosen the two nuts to remove the U-bolts.
  - Lift the saddle far enough to get your fingers under it. With your fingers, roll the vane so it will fit through the hole while continuing to lift the water flow indicator.
- Caution: inspect and make sure the vane lifts from the pipe, otherwise will block the pipe.

## Maintenance & Service

### 1. Quarterly Inspection

- Inspection requirement: appearance and marking inspection, function of the start and reset of the water flow indicator; accuracy of signal delivery.
  - Inspection operation: check the appearance of the water flow indicator; open the test & drain assembly and test valve of the floor, and verify the signal action of the water flow indicator from the fire control equipment; close the test & drain assembly and test valve, and verify the signal reset of the water flow indicator from the fire control equipment.
2. When the water flow indicator is damaged from fire or other causes, replace for a new one immediately.
3. The retard and switch assembly are easily replaceable at field. Contact the sales agent if there is problem with any parts.

## Transportation and Storage

- During transportation, take care to prevent violent vibration, throwing, collision, etc., and with proper protection from rain or chemical erosion.
- When receiving the water flow indicators, check and confirm if there's damage during transportation, and put them on the ground carefully.
- The water flow indicator should be stored in a clean, dry, well-ventilated place with non-corrosive environment.

### HEAD OFFICE - FACTORY

Atatürk Sanayi Bölgesi Hadımköy Mahallesi Mustafa İnan Caddesi No: 44 Arnavutköy - İSTANBUL  
Tel: +90 212 771 01 45 (pbx) | Fax: +90 212 771 47 27  
info@ayvaz.com | www.ayvaz.com

# Water Flow Indicator (AWFD)



## 3. Installation

### 3.1 Hole Cutting



#### a. Hole Cutting Size

Size	Hole Cutting Size (mm)
60/73/76	32(±2)
89/114/140/141/165/168/219	51(±2)

b. Hole position: Hole must be drilled perpendicular to the pipe and vertically centered, otherwise, the vane will conflict the inside pipe and water flow indicator cannot start. The surrounding part around the hole must be smooth, no sunken or bulge.

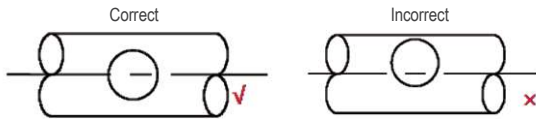

Caution: remove all the materials in the pipe, otherwise, the pipe can be blocked.

### 3.2 Grinding

Deburr to make the hole edge smooth.

Caution: clean the pipe after grinding, no other material inside or outside of the pipe.



### 3.3 Installation



• Water Flow Direction



- Select the correct water flow indicator corresponding to the pipe diameter.
- Check the direction of the water flow, make sure the arrow direction on the saddle same as the water flow direction.

Caution: the arrow direction must be same as the water flow direction, otherwise, the water flow indicator cannot start and function properly.

- Roll the vane, insert the vane into the hole, press the locating slot into the hole, make sure the rubber gasket must be in the locating slot.

Caution: when installed horizontally, the water flow indicator should be at the top of the pipe or side of the pipe, not at the bottom of the pipe.

### 3.4 Fasten the Bolts

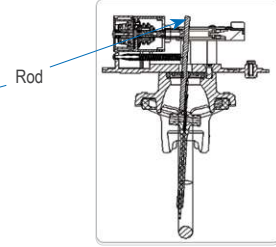

- Mount the U-bolts, fasten the nuts alternately, keep the sealing surface between saddle and pipe evenly.

- Switch the rod to verify if the vane can be active or not. If the vane acts slowly, perform above steps again.

Caution: do not exert force to the signal part when fastening, otherwise, the signal part will be damaged

### 3.5 Wiring

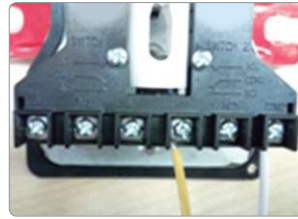

Typical electrical connection:

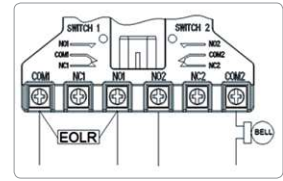

The water flow indicator (AWFD) has two switches, one can be used to operate a central control station, proprietary or remote signaling unit, while the other contact is used to operate a local audible or visual annunciator.

Caution: Cut off the power source when wiring, an uninsulated section of a single conductor should not be looped around the terminal and serve as two separate connections. The wire must be severed, not exposed outside.

### 3.6 Cover The Shell

Cover the shell, fasten the bolts.



## HEAD OFFICE - FACTORY

Atatürk Sanayi Bölgesi Hadımköy Mahallesi Mustafa İnan Caddesi No: 44 Arnavutköy - İSTANBUL

Tel: +90 212 771 01 45 (pbx) | Fax: +90 212 771 47 27

info@ayvaz.com | www.ayvaz.com

# Water Flow Indicator (AWFD)



## Dimension

Nominal Dimension	Size		Dimensions(mm)							Certificate
	DN	Inch	mm	R	A	B	C	D	E	
50	2"	60.3	30.15	116	100	59.5	140	79.5	32	UL FM
65	2 1/2"	73.0	36.5	120	100	59.5	140	79.5	32	UL FM
65	2 1/2"	76.1	38.05	120	100	59.5	140	79.5	32	UL FM
80	3"	88.9	44.45	145	100	59.5	140	80.9	51	UL FM
100	4"	114.3	57.15	185	100	59.5	140	98.5	51	UL FM
125	5"	139.7	69.85	212	100	59.5	140	82.6	51	UL FM
125	5"	141.3	70.65	212	100	59.5	140	82.6	51	UL FM
150	6"	165.1	82.55	254	100	59.5	140	90.4	51	UL FM
150	6"	168.3	84.15	254	100	59.5	140	90.4	51	UL FM
200	8"	219.1	109.55	298	100	59.5	140	90.5	51	UL FM

## Installation & Application

### 1. Pipe Size

Product Size	Nominal Pipe Size		Nominal Pipe O.D. (mm)	Pipe Wall Thickness (mm)			Hole Dia (mm)
	Inch	mm		ASME B36.1 Sch 10	ASME B36.1 Sch 40	BS1387	
60	2	50	60.3	2.77	3.91	3.6	32
73	2 1/2	---	73.0	3.05	5.16	---	32
76	---	65	76.1	---	---	3.6	32
89	3	80	88.9	3.05	5.49	4.0	51
114	4	100	114.3	3.05	6.02	4.5	51
140	---	125	139.7	---	---	5.0	51
141	5	---	141.3	3.4	6.55	---	51
165	---	165	165.1	---	---	---	51
168	6	150	168.3	3.4	7.11	5.0	51
219	8	200	219.1	3.76	8.18	6.3	51

### 2. Caution

- 2.1 Please read the instructions carefully before installation, any damage caused by improper installation will not be liable for the manufacturer.
- 2.2 Before installation, check the nominal diameter, nominal pressure, temperature range and fluid of the water flow indicator, do not install if the technical parameter of the water flow indicator don't match the requirement of the pipe system.
- 2.3 Installation must be performed by qualified personnel and in accordance with all national and local codes and ordinances.
- 2.4 The water flow indicator can be mounted on horizontal or vertical pipe. On horizontal pipe it should be on the top of the pipe or the side of the pipe, do not at the bottom of the pipe. On vertical pipe it should be mounted on the pipe which the water flow is upward.
- 2.5 The pipe length before and after the water flow indicator must be no less than 5 times the pipe diameter, and choose the correct water flow indicator according to the pipe nominal diameter technical parameter table.
- 2.6 The water flow direction must be same as the arrow direction, must not be installed in opposite direction.
- 2.7 Leave enough space for easy installation and maintenance.
- 2.8 Turn off electrical power before installation or maintenance, otherwise will cause serious injury or casualties.
- 2.9 Do not use in inflammable and explosive environment, otherwise will cause serious injury or casualties.

#### HEAD OFFICE - FACTORY

Atatürk Sanayi Bölgesi Hadımköy Mahallesi Mustafa İnan Caddesi No: 44 Arnavutköy - İSTANBUL  
Tel: +90 212 771 01 45 (pbx) | Fax: +90 212 771 47 27  
info@ayvaz.com | www.ayvaz.com

## Water Flow Indicator (AWFD)



### Product Review

The water flow indicator with delay function (AWFD) is designed according to GB5135.7 and UL346 and FM1042.

The water flow indicator is an important part of the automatic sprinkler system, usually installed in the main pipe or branch pipe of the pipe system. When the vane detects the water flow, the water flow signal will be converted to electrical signal, and then switch on the alarm system or start the fire pump directly, at the same time, the fire zone will be indicated.

### Design and Dimensions

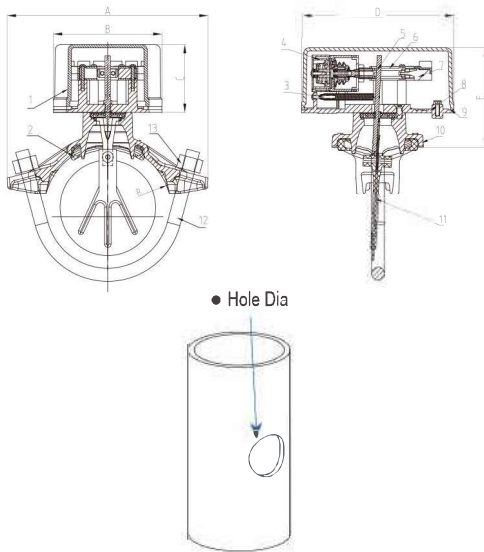

### Product Feature

- Adjustable delay function  
Adjust with rotating switch, accurate adjustable time within 0~90 seconds, high reliability.
- Air delay device with miniature bearing  
Time consistency and reliability are assured
- Adjustable spring design  
Convenient sensitivity adjustment, easy maintenance.
- Double micro switch design  
One end can be used to operate the central control room, and the other end can be used to connect the alarm apparatus.
- Surface treatment  
Red epoxy coating, high corrosion resistance performance

### Specification

Application	Fire protection system
Diameter	2"/DN50-8"/DN200
Working Pressure	2"/DN50-8"/DN200: PN25/363PSI
Flow Sensitivity Range	15-37.5L/MIN
Temperature Range	0-68°C
Fluid	Water
Contact Rating	125/250VAC 5A 24/30VDC 3A

### Standard

- STANDARD FOR INSTALLATION OF SPRINKLER SYSTEM NFPA-13
- ONE-AND TWO-FAMILY DWELLINGS AND MANUFACTURED HOMES INSTALLATION OF SPRINKLER SYSTEMS NFPA-13D
- STANDARD FOR THE INSTALLATION OF SPRINKLER SYSTEM IN LOW-RISE RESIDENTIAL OCCUPANCIES NFPA-13R
- NATIONAL FIRE ALARM CODE NFPA-72

### Material Specifications

Part No.	Part	Material
1	Cover	ASTM B85-96 383.0E
2	Rubber Gasket	EPDM
3	Spring	SS304
4	Air Delay Device	PC GV3410R
5	Stem Sealing Gasket	SS304+NBR
6	Connecting Rod	POM 500P
7	Micro-Switch	PC GV3410R
8	Connection Plate	ASTM B85-96 383.0E
9	Connection Plate Seal	NBR
10	Saddle	ASTM A536,65-45-12
11	Vane	PTFE
12	U-Bolts	Carbon Steel Zinc Plated
13	Nuts	Carbon Steel Zinc Plated

#### HEAD OFFICE - FACTORY

Atatürk Sanayi Bölgesi Hadımköy Mahallesi Mustafa İnan Caddesi No: 44 Arnavutköy - İSTANBUL  
Tel: +90 212 771 01 45 (pbx) | Fax: +90 212 771 47 27  
info@ayvaz.com | www.ayvaz.com